

USER'S MANUAL

BM065s

Compact AC/DC Clamp-on Multimeter Series



BRYMEN CZ-SK
 Ing. Petr Kotas Komponenty a přístroje elektro
www.in-electric.cz www.k-electric.eu www.koel.cz

1) SAFETY

This manual contains information and warnings that must be followed for operating the instrument safely and maintaining the instrument in a safe operating condition. If the instrument is used in a manner not specified by the manufacturer, the protection provided by the instrument may be impaired.

The meter protection rating, against the users, is double insulation per IEC61010-1 2nd Ed., EN61010-1 2nd Ed., UL61010-1 2nd Ed., CAN/CSA C22.2 No. 61010-1, 2nd Ed., IEC61010-2-032, EN61010-2-032, UL61010B-2-032 and CAN/CSA C22.2 No. 61010-2-032-04:

Category CAT III 600V AC & DC.

PER IEC61010 OVERVOLTAGE INSTALLATION CATEGORY

OVERVOLTAGE CATEGORY II

Equipment of OVERVOLTAGE CATEGORY II is energy-consuming equipment to be supplied from the fixed installation.

Note – Examples include household, office, and laboratory appliances.

OVERVOLTAGE CATEGORY III

Equipment of OVERVOLTAGE CATEGORY III is equipment in fixed installations.

Note – Examples include switches in the fixed installation and some equipment for industrial use with permanent connection to the fixed installation.

OVERVOLTAGE CATEGORY IV

Equipment of OVERVOLTAGE CATEGORY IV is for use at the origin of the installation. Note – Examples include electricity meters and primary over-current protection equipment.

TERMS IN THIS MANUAL

WARNING identifies conditions and actions that could result in serious injury or even death to the user.

CAUTION identifies conditions and actions that could cause damage or malfunction in the instrument.

WARNING

To reduce the risk of fire or electric shock, do not expose this product to rain or moisture. The meter is intended only for indoor use.

To avoid electrical shock hazard, observe the proper safety precautions when working with voltages above 60 VDC or 30 VAC rms. These voltage levels pose a potential shock hazard to the user.









Keep your hands/fingers behind the hand/finger barriers (of the meter and the test leads) that indicate the limits of safe access of the hand-held part during measurement. Inspect test leads, connectors, and probes for damaged insulation or exposed metal before using the instrument. If any defects are found, replace them immediately.

This Clamp-on meter is designed to apply around or remove from uninsulated hazardous live conductors. But still, individual protective equipment must be used if hazardous live parts in the installation where measurement is to be carried out could be accessible.

CAUTION

Disconnect the test leads from the test points before changing meter functions.

INTERNATIONAL ELECTRICAL SYMBOLS

	Caution ! Refer to the explanation in this Manual
	Caution ! Risk of electric shock
	Earth (Ground)
	Double Insulation or Reinforced insulation
	Fuse
	AC--Alternating Current
	DC--Direct Current
	Application around and removal from hazardous live conductors is permitted

2) CENELEC Directives

The instruments conform to CENELEC Low-voltage directive 2006/95/EC and Electromagnetic compatibility directive 2004/108/EC

3) PRODUCT DESCRIPTION

Note: Top of the line model is used as representative for illustration purposes. Please refer to your respective model for function availability.

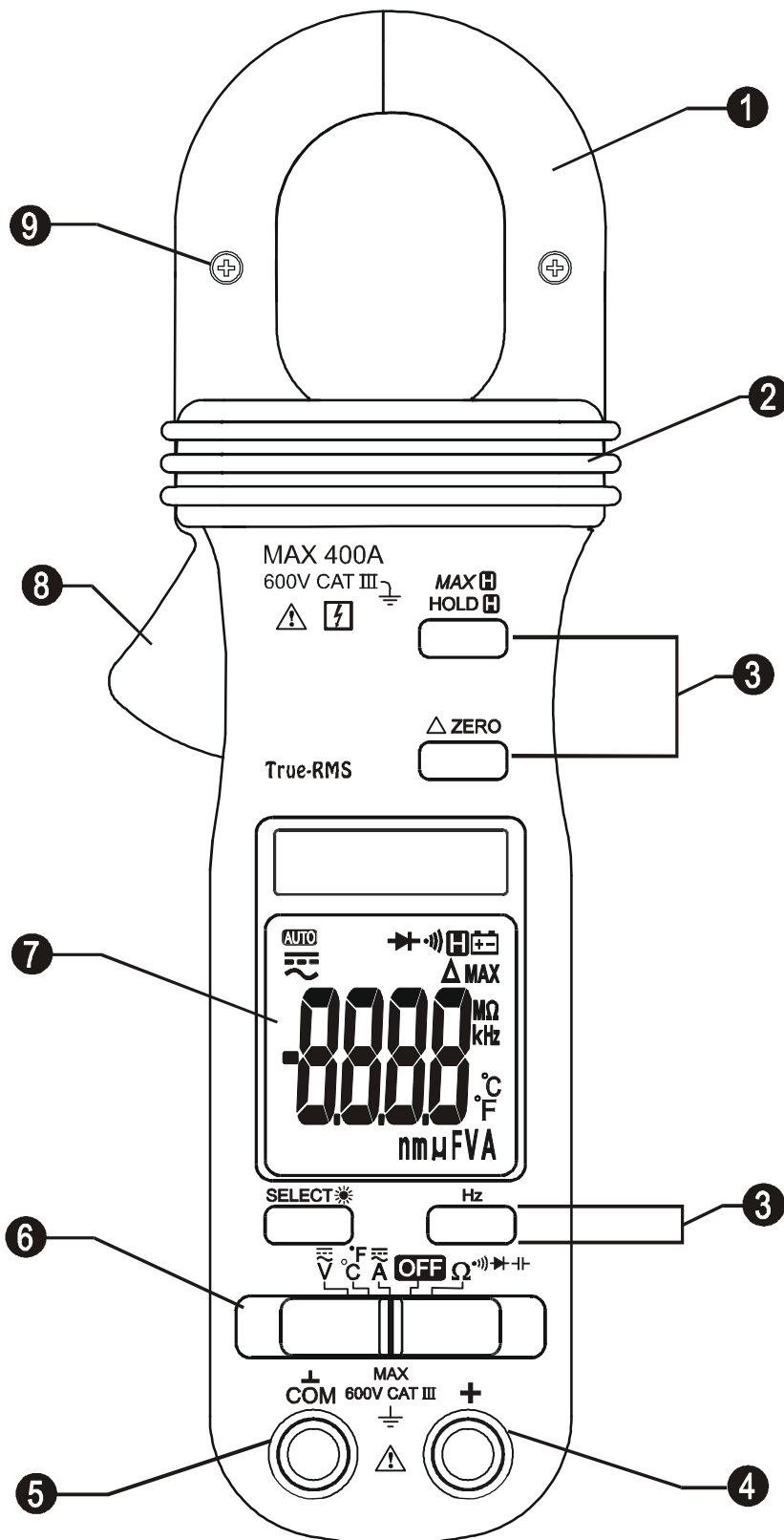

1) Hall-effect Clamp Jaw for AC & DC current magnetic field pick up

2) Hand/Finger Barrier to indicate the limits of safe access of the meter during measurement

3) Push-buttons for special functions & features

4) Input Jack for all functions EXCEPT non-invasive ACA & DCA current functions

5) Common (Ground reference) Input Jack for all functions EXCEPT non-invasive ACA & DCA current functions

6) Slide-switch Selector to turn the power ON/OFF and Select a function

7) 3-3/4 digits 4000 counts LCD display

8) Jaw trigger for opening the clamp jaw

9) DCA direction for + polarity as well as Jaw center Indicator, at where best ACA & DCA accuracy is specified

4) OPERATION

CAUTION: Before and after hazardous voltage measurements, test the voltage function on a known source such as line voltage to determine proper meter functioning.

DC Voltage, AC Voltage, Hz Frequency functions

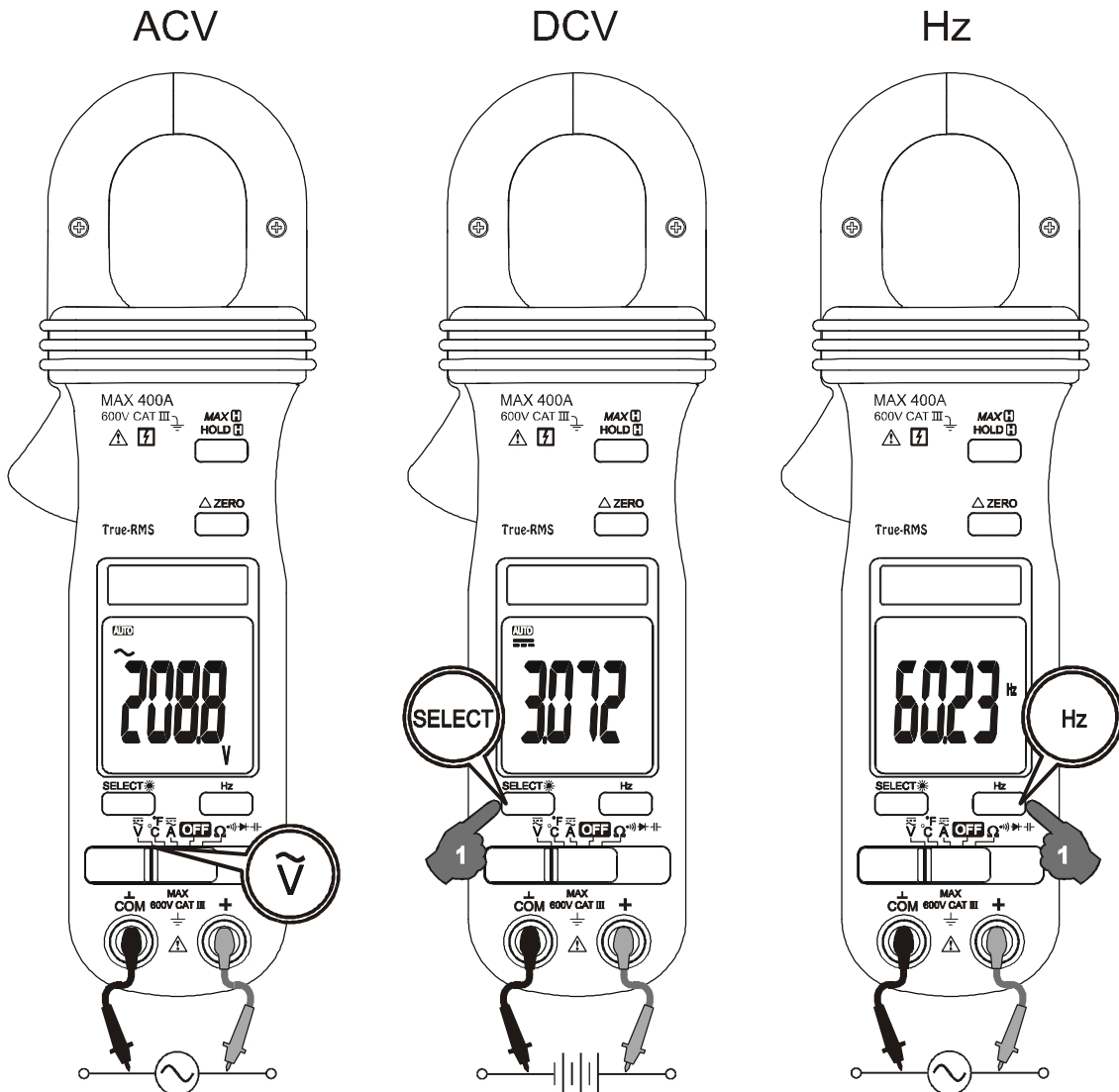

Set slide-switch to Voltage function position. Inputs are made through the test leads terminals. For Models 063 & 065, slide-switch on defaults at AC voltage. Press **SELECT** button momentarily to select DC voltage. For Models 061 & 062, separate ACV & DCV slide-switch positions are being used.

Press the Hz button momentarily to activate Hz Frequency. The Hz trigger level is determined by the selected function-range from where the Hz function is activated. In ACV function, activating the Hz function during significant measurements can get the most appropriate trigger level to avoid electrical noises in most cases. Electrical noise may cause unstable Hz reading. Activating the Hz function at AC 4.000V range (before making significant measurements) can get lower trigger level (higher sensitivity). Hz reading may show zero when the sensitivity is insufficient.

Note: DC 400.0mV range is designed with 1000MW high input impedance for least current drain in measuring small signals, and can cope better with most commercially available voltage output transducers/adapters. The non-zero display reading is normal when the meter inputs are open circuit, which will not affect actual measurement accuracy. The meter will show close-to-zero readings when the inputs are shorted. Open input is actually a floating condition, which is not a zero-volt-input condition.

ACA & DCA Current clamp-on function

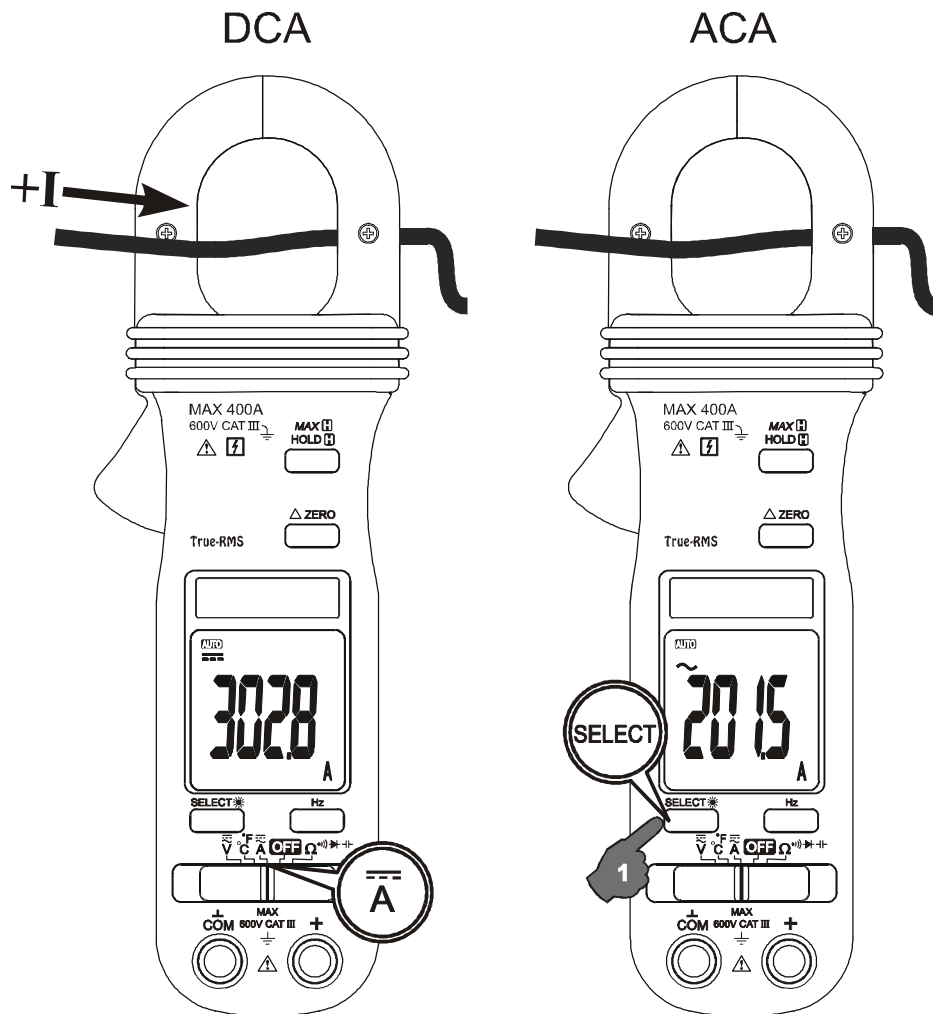

Inputs are made through the clamp jaws for non-invasive ACA & DCA current measurements.

CAUTION (Application and removal of the Clamp-on meter)

Press the jaw trigger and clamp the jaws around only one single conductor of a circuit for load current measurement. Make sure the jaws are completely closed, or else it will introduce measurement errors. Enclosing more than one conductor of a circuit will result in differential current measurement (like identifying leakage current). Locate the conductor(s) at the Jaws center as much as possible to get the best measuring accuracy. The jaw “+” mark indicates current flow direction on DCA positive readings.

For removal, press the jaw trigger and remove the jaws from the conductor(s).

Note: In DCA measurements, hysteresis of the jaws (after measuring high DC currents) may introduce non-zero residual readings. Relative Zero Δ mode should be used each time to offset the residual readings, if any, for more accurate measurements.

Adjacent current-carrying devices such as transformers, motors and conductor wires will affect measurement accuracy. Keep the jaws away from them as much as possible to minimize influence.

Resistance, and \rightarrow) Continuity functions

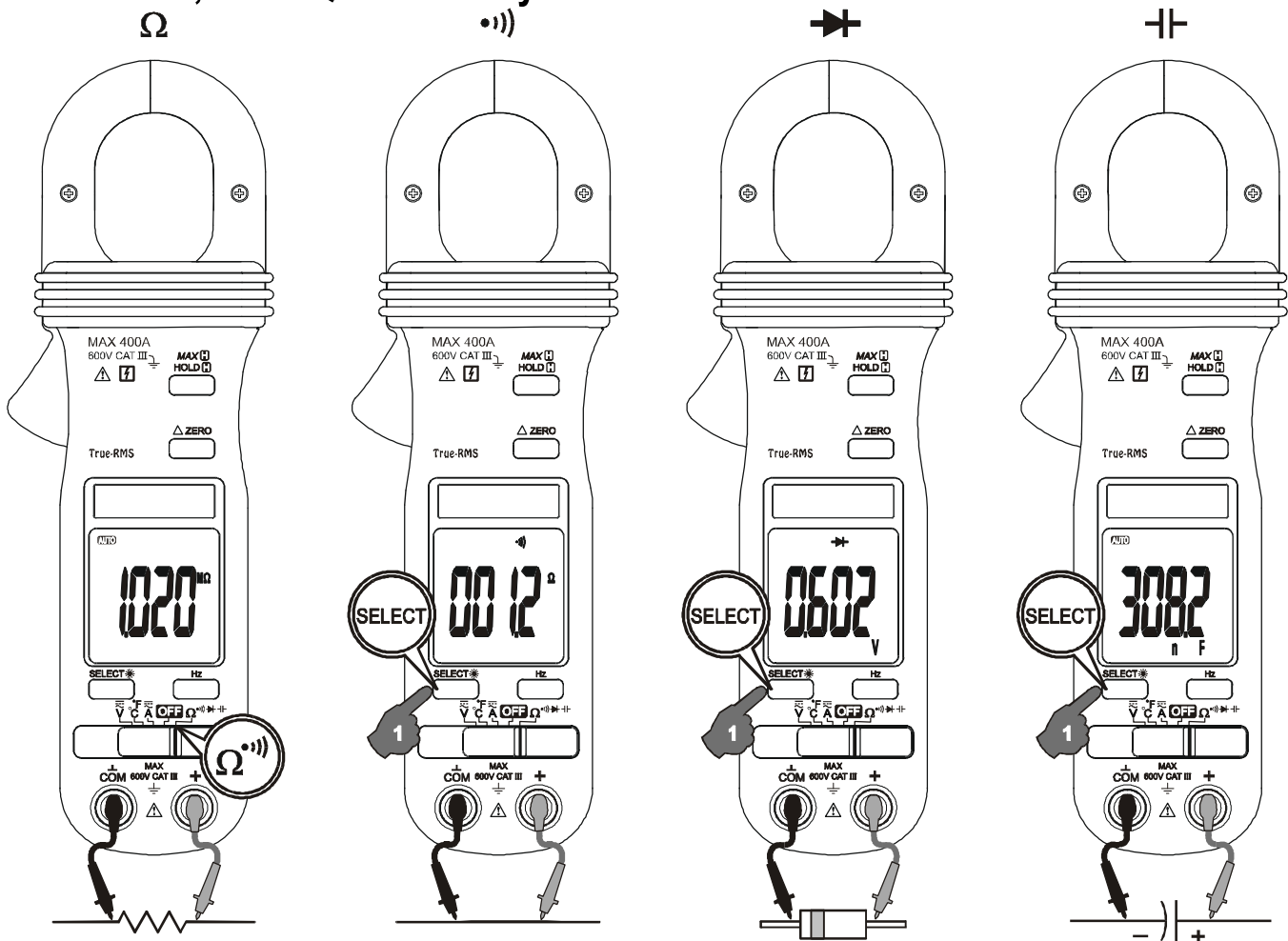

CAUTION

Using Resistance, Continuity or Diode function in a live circuit will produce false results and may damage the instrument. In many cases the suspected component must be disconnected from the circuit to obtain an accurate measurement reading

Inputs are made through the test leads terminals. Slide-switch on defaults at V. Press **SELECT** button momentarily to select \bullet)) Continuity function which is convenient for checking wiring connections and operation of switches. A continuous beep tone indicates a complete wire.

→ Diode test function

Inputs are made through the test leads terminals. Slide-switch on defaults at V . Press **SELECT** button momentarily 2 times to select **→** Diode test function. Normal forward voltage drop (forward biased) for a good silicon diode is between 0.400V to 0.900V. A reading higher than that indicates a leaky diode (defective). A zero reading indicates a shorted diode (defective). An OL indicates an open diode (defective). Reverse the test leads connections (reverse biased) across the diode. The digital display shows OL if the diode is good. Any other readings indicate the diode is resistive or shorted (defective).

⇄ Capacitance function

Inputs are made through the test leads terminals. Slide-switch on defaults at V . Press **SELECT** button momentarily 3 times to select **⇄** Capacitance function. Relative zero Δ mode can be used to zero out the parasitic capacitance of the leads and the internal protection circuitry of the meter when measuring low capacitance in the order of Pico Farad (pF).

CAUTION

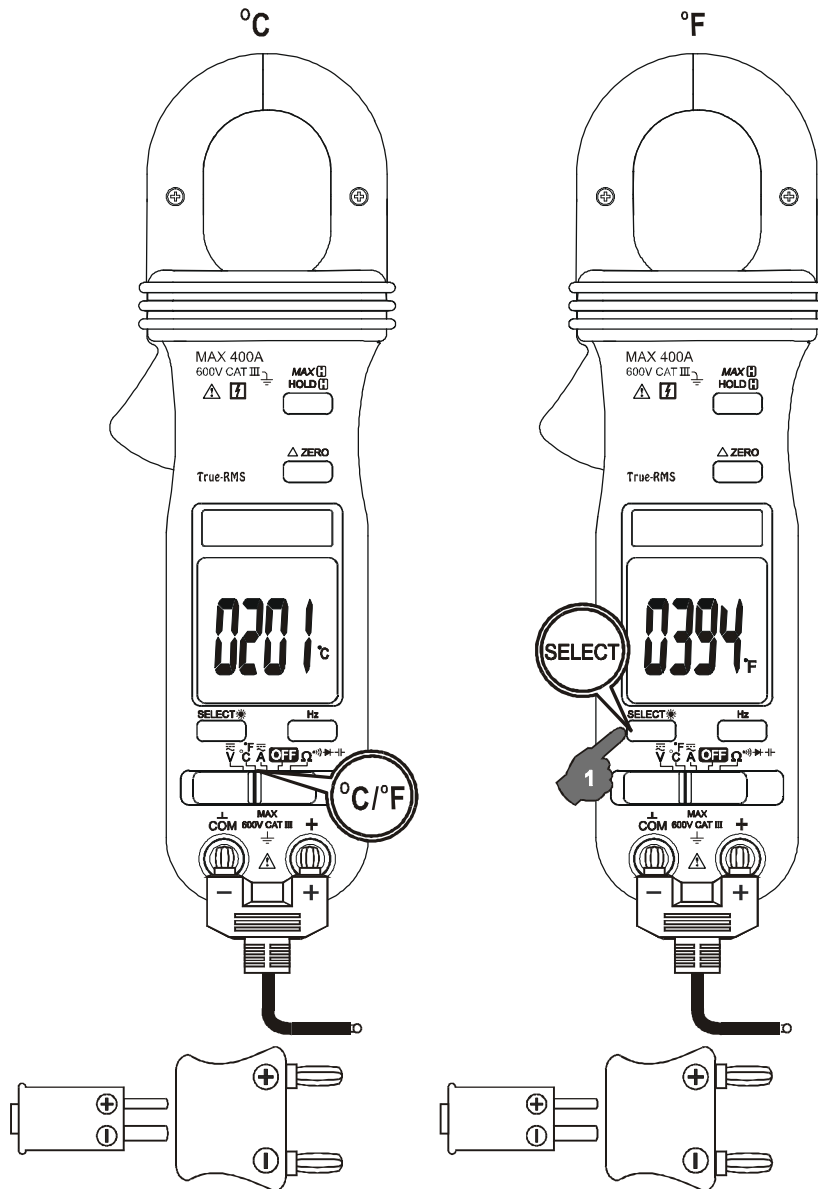

Discharge capacitors before making any measurement. Large value capacitors should be discharged through an appropriate resistance load

Temperature function (Model 065 & 063 only)



Be sure to insert the banana plug type-K temperature bead probe Bkp60 with correct **+ -** polarities. Slide-switch on defaults at degree C (Celsius). Press **SELECT** button momentarily to select degree F (Fahrenheit). You can also use a plug adapter Bkb32 (Optional purchase) with banana pins to type-K socket to adapt other type-K standard mini plug temperature probes.

HOLD

The Hold feature freezes the display for later viewing. Press the **HOLD**  button momentarily to toggle to the Hold feature. The annunciator “” turns on.

MAX

The max feature compares and displays the measured maximum value as fast as

30ms with auto-ranging capability. It allows the meter to capture in-rush currents in current functions. Press and hold the **MAX** button for 1 second or more to toggle to the max feature. The annunciators “**MAX**” and “**☐**” turn on.

Relative Zero Δ mode

Relative Zero Δ mode allows the user to offset the meter consecutive measurements with the displaying reading as the reference value. The display will now show readings relative to the stored reference value. That is, display = reading - stored value. Press the Δ button momentarily to toggle to the relative zero mode. The annunciator “ Δ ” turns on. The meter also enters manual ranging mode where available. The annunciator “**AUTO**” turns off.

Display Backlight (Model 065 & 062 only)

Press the **SELECT** button for 1 second or more to toggle the display backlight on and off.

Auto Power Off (APO)

When the meter is on, the Auto Power Off (APO) feature will switch the meter to sleep mode automatically after approximately 30 minutes of neither slide-switch nor push button operations to extend battery life. To wake up the meter from APO, press any push-button momentarily or set the slide-switch to the OFF position and then slide back on again. Always set the slide-switch to the OFF position manually when the meter is not in use.

5) MAINTENANCE

WARNING

To avoid electrical shock, disconnect the meter from any circuit, remove the test leads from the input jacks and turn OFF the meter before opening the case. Do not operate with open case.

Trouble Shooting

If the instrument fails to operate, check batteries and test leads etc., and replace as necessary. Double check operating procedure as described in this user's manual

If the instrument voltage-resistance input terminal has subjected to high voltage transient (caused by lightning or switching surge to the system) by accident or abnormal conditions of operation, the series fusible resistors will be blown off (become high impedance) like fuses to protect the user and the instrument. Most measuring

functions through this terminal will then be open circuit. The series fusible resistors and the spark gaps should then be replaced by qualified technician. Refer to the LIMITED WARRANTY section for obtaining warranty or repairing service.

Cleaning and Storage

Periodically wipe the case with a damp cloth and mild detergent; do not use abrasives or solvents. If the meter is not to be used for periods of longer than 60 days, remove the batteries and store them separately

Battery replacement

The meter uses standard 1.5V AAA Size (NEDA 24G or IEC R03) battery X 2; or 1.5V AAA Size (NEDA 24A or IEC LR03) alkaline battery X 2.

Loosen the 2 captive screws from the battery cover case. Lift the battery cover case. Replace the batteries. Replace battery cover case. Re-fasten the screws.

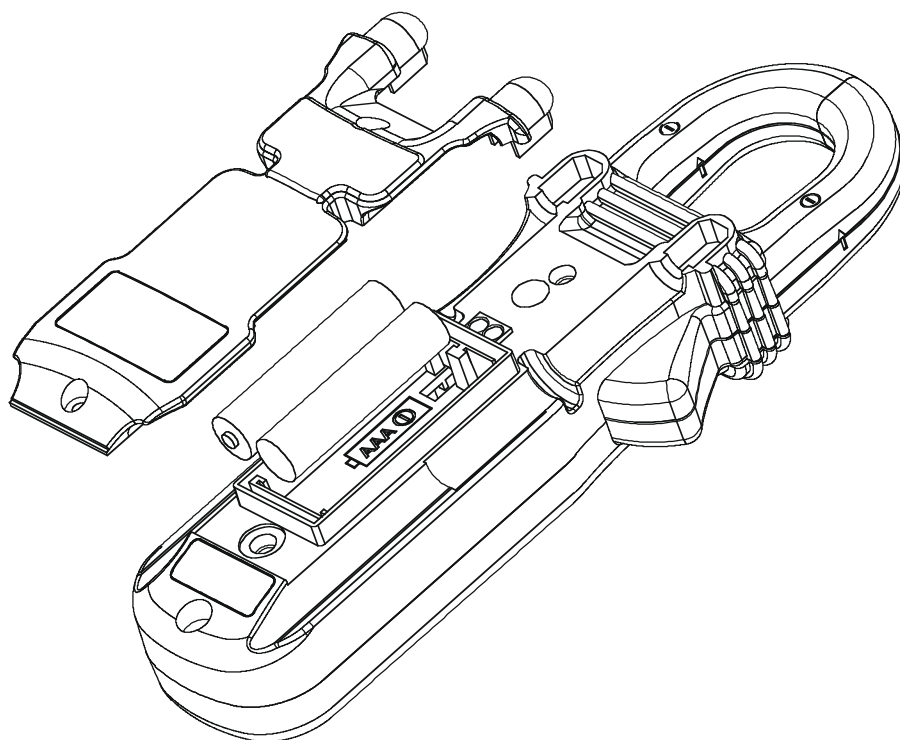

6) SPECIFICATIONS

Display : 3-3/4 digits 4000 counts LCD display(s)

Update Rate : 3 per second nominal

Polarity : Automatic

Low Battery : Below approx. 2.4V

Operating Temperature : 0°C to 40°C

Relative Humidity : Maximum relative humidity 80% for temperature up to 31°C decreasing linearly to 50% relative humidity at 40°C

Altitude : Operating below 2000m

Storage Temperature : -20°C to 60°C, < 80% R.H. (with battery removed)

Temperature Coefficient : nominal $0.15 \times (\text{specified accuracy}) / ^\circ\text{C}$ @ (0°C -18°C or 28°C -40°C), or otherwise specified

Sensing : Average sensing for Models 061 & 063; True RMS for Models 062 & 065

Safety : Meets IEC61010-1 2nd Ed., EN61010-1 2nd Ed., UL61010-1 2nd Ed., CAN/CSA C22.2 No. 61010.1-0.92, IEC61010-2-032, EN61010-2-032 & UL61010B-2-032 and CAN/CSA C22.2 No. 61010-2-032-04:

Category III 600 Volts ac & dc.

Transient protection : 6.5kV (1.2/50ms surge) for all models

Pollution degree : 2

E.M.C. : Meets EN61326-1:2006 (EN55022, EN61000-3-2, EN61000-3-3, EN61000-4-2, EN61000-4-3, EN61000-4-4, , EN61000-4-5, EN61000-4-6, EN61000-4-8, EN61000-4-11)

In an RF field of 3V/m:

Capacitance function is not specified

Other function ranges: Total Accuracy = Specified Accuracy + 50igits

Performance above 3V/m is not specified

Overload Protections :

Clamp-on jaws : DC/AC 400A rms continuous

+ & COM terminals (all functions) : 600VDC/VAC rms

Power Supply : standard 1.5V AAA Size (NEDA 24G or IEC R03) battery X 2; or 1.5V AAA Size (NEDA 24A or IEC LR03) alkaline battery X 2

Power Consumption : 11mA typical for ACA/DCA and 2.9mA typical for other functions

APO Timing : Idle for 30 minutes

APO Consumption : typical 10mA for Model 061 & 063 and 190mA for Model 062 & 065

Dimension : L188mm X W63mm X H40mm

Weight : 218 gm approx

Jaw opening & Conductor diameter : 30mm max

Accessories : Test lead pair, batteries installed, user's manual, soft carrying pouch, & BKP60 banana plug type-K thermocouple (model 063 & 065 only)

Optional accessories : BKB32 banana plug to type-K socket plug adaptor (model 063 & 065 only)

Electrical Specifications

Accuracy is \pm (% reading digits + number of digits) or otherwise specified, at $23^{\circ}\text{C} \pm 5^{\circ}\text{C}$ & less than 75% R.H.

True RMS Model 062 & 065 ACV & ACA clamp-on accuracies are specified from 5% to 100% of range or otherwise specified. Maximum Crest Factor are as specified below, and with frequency spectrums, besides fundamentals, fall within the meter specified AC bandwidth for non-sinusoidal waveforms. Fundamentals are specified at 50Hz and 60Hz.

DC Voltage

RANGE	Accuracy
400.0 mV	0.3% + 3d
4.000V, 40.00V, 400.0V	0.5% + 3d
600V	1.0% + 4d

Input Impedance : 10MW, 30pF nominal (1000MW for 400.0mV range)

AC Voltage

RANGE	Accuracy
50Hz ~ 60Hz	
4.000V, 40.00V, 400.0V	1.0% + 4d
60Hz ~ 500Hz	
4.000V, 40.00V, 400.0V	1.5% + 4d
50Hz ~ 500Hz	
600V	2.0% + 4d

Input Impedance: 10MW, 30pF nominal

True RMS Model 062 & 065 Crest Factor:

< 2 : 1 at full scale & < 4 : 1 at half scale

Ohms

RANGE	Accuracy
400.0W	0.8% + 6d
4.000kW, 40.00kW, 400.0kW	0.6% + 4d
4.000MW	1.0% + 4d
40.00MW	2.0% + 4d

Open Circuit Voltage : 0.4VDC typical

Audible Continuity Tester

Open Circuit Voltage: 0.4VDC typical

Range: 400.0W, Accuracy: 1.5% + 8d

Audible threshold: between 10W and 120W.

Diode Tester

Open Circuit Voltage : < 1.6 VDC Typical

Test Current : 0.4mA Typical

Capacitance

RANGE ¹⁾	Accuracy ^{2) 3)}
500.0nF, 5.000nF, 50.00nF, 500.0nF, 3000mF	3.5% + 6d

¹⁾Additional 50.00nF range accuracy is not specified

²⁾Accuracies with film capacitor or better

³⁾Specified with battery voltage above 2.8V (approximately half full battery). Accuracy decreases gradually to 12% at low battery warning voltage of approximately 2.4V

DCA Current (Clamp-on)

RANGE	Accuracy ^{1) 2)}
400.0A	
0A ~ 50.0A	1.0% + 4d
50.0A ~ 200.0A	1.5% + 5d
200.0A ~ 300.0A	2.0% + 5d
300.0A ~ 400.0A	2.5% + 5d

¹⁾Induced error from adjacent current-carrying conductor: < 0.01A/A

²⁾Relative Zero Δ mode is applied to offset the non-zero residual readings, if any

ACA Current (Clamp-on)

RANGE	Accuracy¹⁾
400.0A	
40Hz ~ 60Hz @ 0 ~ 50A	1.0% + 6d
60Hz ~ 400Hz @ 0 ~ 50A	1.5% + 5d
40Hz ~ 60Hz @ 50A ~ 200A	1.5% + 5d
60Hz ~ 200Hz @ 50A ~ 200A	2.0% + 5d
40Hz ~ 60Hz @ 200A ~ 300A	2.0% + 5d
40Hz ~ 60Hz @ 300A ~ 400A	2.5% + 5d

¹⁾Induced error from adjacent current-carrying conductor: < 0.01A/A

True RMS Model 062 & 065 Crest Factor:

< 1.8 : 1 at full scale & < 3.6 : 1 at half scale

Hz Frequency

Function	Sensitivity (Sine wave)	Range
400.0mV	350mV	10Hz ~ 1kHz
4.000V	3.2V	5Hz ~ 20kHz
40.00V	25V	5Hz ~ 100kHz
400.0V	100V	5Hz ~ 100kHz
600V	410V	5Hz ~ 5kHz
DCA/ACA	Unspecified	

Display counts: 5000

Maximum resolution: 0.001Hz

Accuracy: 0.5%+4d

Type-K Temperature (Model 063 & 065 only)

RANGE	Accuracy
-20 °C ~ 300 °C	2.0% + 3d
300 °C ~ 537 °C	3.0% + 3d
-4 °F ~ 572 °F	2.0% + 6d
572 °F ~ 1000 °F	3.0% + 6d

Type-K thermocouple range & accuracy not included

LIMITED WARRANTY

BRYMEN warrants to the original product purchaser that each product it manufactures will be free from defects in material and workmanship under normal use and service within a period of one year from the date of purchase. BRYMEN's warranty does not apply to accessories, fuses, fusible resistors, spark gaps, batteries or any product which, in BRYMEN's opinion, has been misused, altered, neglected, or damaged by accident or abnormal conditions of operation or handling.

To obtain warranty service, contact your nearest BRYMEN authorized agent or send the product, with proof of purchase and description of the difficulty, postage and insurance prepaid, to BRYMEN TECHNOLOGY CORPORATION. BRYMEN assumes no risk for damage in transit. BRYMEN will, at its option, repair or replace the defective product free of charge. However, if BRYMEN determines that the failure was caused by misused, altered, neglected, or damaged by accident or abnormal conditions of operation or handling, you will be billed for the repair.

THIS WARRANTY IS EXCLUSIVE AND IS IN LIEU OF ALL OTHER WARRANTIES, EXPRESSED OR IMPLIED, INCLUDING BUT NOT LIMITED TO ANY IMPLIED WARRANTY OR MERCHANTABILITY OR FITNESS FOR A PARTICULAR PURPOSE OR USE. BRYMEN WILL NOT BE LIABLE FOR ANY SPECIAL, INDIRECT, INCIDENTAL OR CONSEQUENTIAL DAMAGES.



BRYMEN TECHNOLOGY CORPORATION

TEL:+886 2 2226 3396

FAX:+886 2 2225 0025

<http://www.brymen.com>

